

Features

- DALI or PUSH dimmable, time dimming
- Output current and parameters set via NFC or Lifud programmer
- Luminaire temperature guard via external NTC resistor
- Driver temperature guard via internal OTP protection
- Surge protection: L-N: 6kV; L/N-PE: 10kV
- Complies with Zhaga Book 13
- IP20; suitable for Class I/II light fixtures (IP>54)



Applications

· Street lighting · area lighting · industry lighting

Descriptions

LF-ACD040A-1050-57 is a 40W (max.) DALI NFC dimmable constant current LED driver. Its rated input voltage ranges from 220 to 240Vac. Its output current is adjustable from 200 to 1050mA. It has protective features of input over voltage, output open circuit, output short-circuit protection and internal & external temperature protection.

Product Model

LF - ACD 040A -1050 - 57

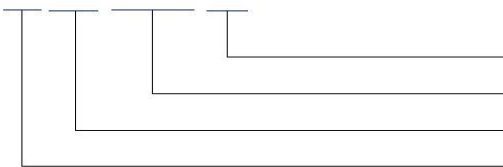

- 57: max. output voltage: 57Vdc
- 1050: max. output current: 1050mA
- 040: max. output power: 40W; A: DALI-2 series
- ACD: DALI dimmable LED driver

Lifud Technology Co., Ltd.

Add.: 3AF, Block B, Xingzhan Plaza, No.446, Nanhuan Rd., Shajing St., Bao'an Dist., Shenzhen, Guangdong, China
 Factory I: Lifud Gardern-style Industrial Park, Tianfu New Dist., Meishan City, Sichuan, China
 Factory II: Lifud Intelligent Manufacture Industrial Park, Zhichuang Rd., Banfu Town, Zhongshan, Guangdong, China
 Website: www.lifud.com Telephone: +86(0)755 8373 9299 Email: sales@lifud.com

■ Electrical Characteristics

Model		LF-ACD040A-1050-57				
Output	Output Voltage	17-57V				
	Output Current	200-1050mA ^① (default: 700mA ^②)				
	Ripple Current ($\leq 100\text{Hz}$)	$\pm 3.3\%$				
	Flicker Index	IEC-Pst ≤ 1 , CIE SVM ≤ 0.4 , Complies with IEEE Std 1789-2015				
	Current Tolerance	$\pm 5\%$				
	Temperature Drift	$\pm 10\%$				
	Start-up time	<1.5s				
Input	Rated Input Voltage	220-240Vac				
	Input Voltage Range	180-264Vac				
	DC Input Voltage	180-264Vac ^③				
	Input Frequency	0/50/60Hz				
	Input Current	0.3A max.				
	PF	≥ 0.95				
	THD	<10%				
	Efficiency	$\geq 89\%$				
	Inrush Current	<30A&150uS				
	Loading Quantities of Circuit Breaker	Model	B10	C10	B16	C16
		Quantity (pcs)	22	22	35	35
	Leakage Current	<0.7mA				
	Standby Power Consumption	$\leq 0.35\text{W}$ (DALI OFF)				
Environment Descriptions	Operating Temperature	$-40^{\circ}\text{C}\sim+55^{\circ}\text{C}$				
	Operating Humidity	20-90%RH (no condensation)				
	Storage Temperature/Humidity	$-40^{\circ}\text{C}\sim+80^{\circ}\text{C}$ (6 months in Class I environment); 10-90%RH (no condensation)				
	Atmospheric Pressure	86-106kPa				
Surge	L-N	6kV				
	L/N-PE	10kV				
	PUSH	0.5kV				

■ Electrical Characteristics

Safety and EMC	Certifications	ENEC, CE, CB, UKCA, RCM, SAA
	Withstanding Voltage	I/P-O/P: 3.75kV&5mA&60S;I/P-PE: 1.5kV&5mA&60S;O/P-PE: 1.5kV&5mA&60S; I/P-DA1/DA2: 1.5kV&5mA&60S;O/P-DA1/DA2: 1.5kV&5mA&60S
	Insulation Resistance	I/P-O/P:>100MΩ@500VDC;I/P-PE:>100MΩ@500VDC;O/P-PE:>100MΩ@500VDC; I/P-DA1/DA2:>100MΩ@500VDC;O/P-DA1/DA2:>100MΩ@500VDC
	Safety Standards	CB:IEC 61347-1:2015, IEC61347-2-3:2014, IEC 61347-2-13:2014/AMD1:2016ERP:EU 2019/2020@2019.12.05 CE-LVD: EN 61347-2-13:2014/A1:2017, EN 61347-1:2015, EN 62493:2015 ENEC: EN61347-1:2015, EN 61347-2-13:2014/A1:2017, EN 62384: 2020 RCM:AS 61347.2-13:2018 SAA:AS61347.2-13:2018
	EMI	CE-EMC/RCM:EN55015, EN61000-3-2, EN61000-3-3 EN IEC 61000-3-2:2019/A1:2021, EN 61000-3-3:2013/A2:2021 UKCA-EMC:EN IEC 55015:2019/A11:2020, EN 61547:2009
	EMS	CE-EMC/RCM: EN61000-4-2,3,4,5,6,11
Other Parameters	IP Rating	IP20
	RoHS	RoHS 2.0 (EU) 2015/863
	Tc Max	90°C
	Warranty Condition	8 years (Tc≤84°C)
	Compatibility of DALI Dimming ^④	Yuanhao Master, Simon Master, Philips Master DDBC120-DALI, OSRAM Master, Helvar Master 905 Router, Tridonic Master and HDL MC64-DALI431 Master
	DALI Standard	IEC62386-101, 102, 207
Noise Level	≤25dB (The noise collector should be tested at 10cm from the driver in a quiet room)	
Testing Equipment	AC power source: CHROMA6530, digital power meter: CHROMA66202, oscilloscope: Tektronix DPO3014, DC electronic load: M9712B, LED board, constant temperature and humidity chamber; Everfine EMS61000-5B, fast transient generator: Everfine EMS61000-4A, spectroanalyzer: KH3935, hi-pot tester: EEC SE7440, flicker tester (flicker-free coefficient test): Everfine LFA-3000, etc.	
Testing Remark	If there are no special remarks, the above parameters are tested at the ambient temperature of 25°C, humidity of 50%, maximum output power and input voltage of 230Vac/50Hz.	

■ **Electrical Characteristics**

<p>Additional Remarks</p>	<ol style="list-style-type: none"> 1. It is recommended that user install the over voltage protection, under voltage protection and surge protection devices in the power supply circuits of light fixtures to ensure electricity safety. 2. The LED driver used in combination with the end device is one of the accessories of the whole light fixture, and the EMC of the whole light fixture is not only susceptible to the driver itself, but to the LED light fixture and the whole light fixture's wiring. Thus, the manufacturer of LED light fixture should re-confirm the EMC of the whole light fixture before the whole light fixture is finished. 3. The PC cover, casing and end cap for assembling the LED driver in the light fixture must meet the fire rating of UL94-V0 or above. 4. The total output power of the driver can not exceed the rated maximum power during use, otherwise it can not be guaranteed. 5. Lifud reserves the right to interpret any of the above parameters. <p>Remark:</p> <ol style="list-style-type: none"> ① When the output current is 1050mA, the load voltage of LED driver ranges from 17 to 38Vdc; when the load voltage >38Vdc, the LED driver outputs with the maximum power of 40W. Please see the chart. ② The default current of LED driver is 700mA and its output current can be set by Lifud programmer and DALI programming software(or FEIG NFC reader). ③ DC input is only for emergency. ④ When using other DALI masters, please test their compatibilities with Lifud LED driver in advance.
----------------------------------	---

■ **Product Characteristic Curves**

Working Window Curve

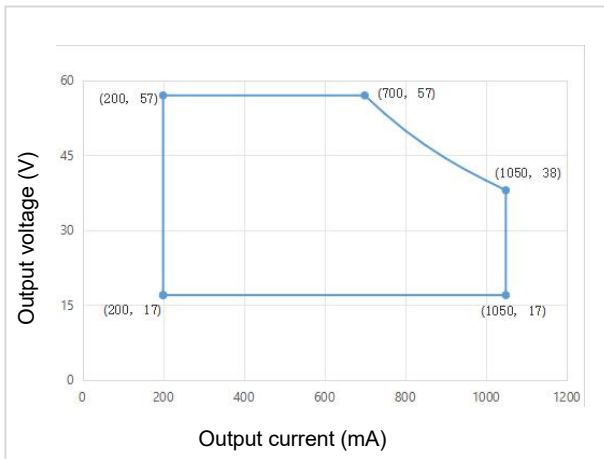

Efficiency Curve

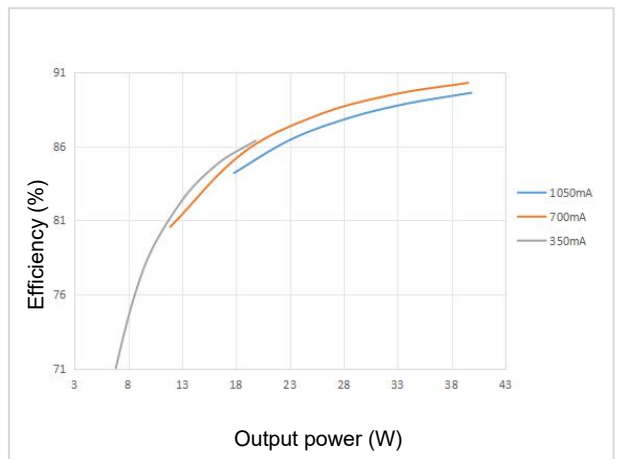

■ Product Characteristic Curves

PF Curve

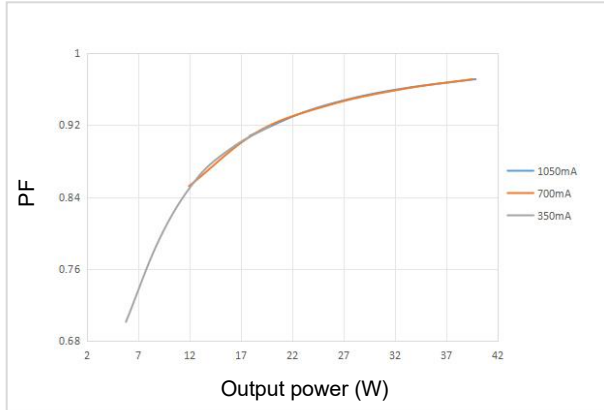

THD Curve

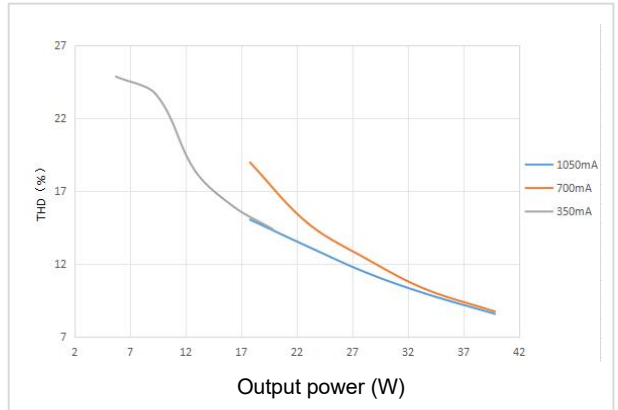

Lifetime Curve

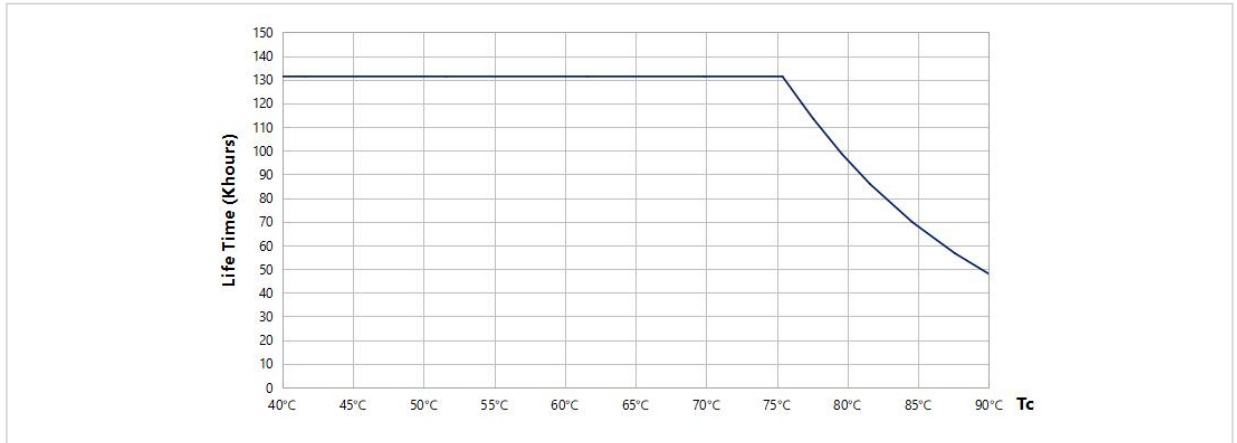

Tc Point (unit: mm)

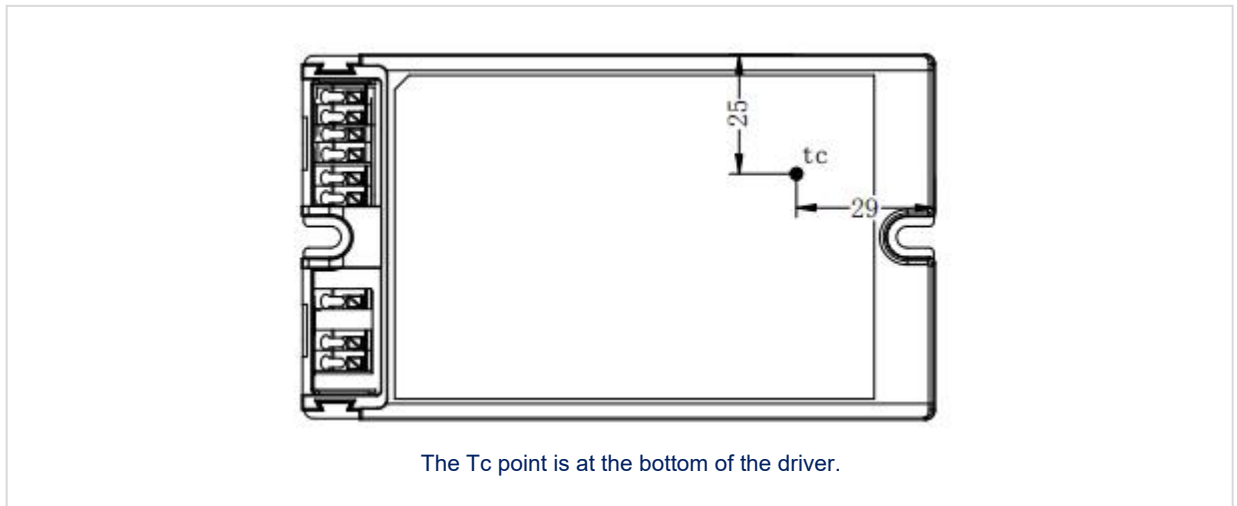

The Tc point is at the bottom of the driver.

■ Protective Characteristics

Protective Type				Min.	Typ.	Max.	Introduction
External over-temperature protection	Mode 1	If the temperature is too high, decrease the current first and then turn off the light.	R1 (Start to decrease the current)	/	1.65kΩ	/	When the external NTC resistance decreases to R1, the external thermal protection is triggered and the output current gradually decreases.
			R2 (Stop decreasing the current)	/	1.27kΩ	/	When the external NTC resistance decreases to R2, the output current drops to the programmed protection current value and stops decreasing (default 50%Io).
			R3 (Turn off the light)	/	1.1kΩ	/	When the external NTC resistance decreases to R3, turn off the light and it needs to restart the AC to restore.
	Mode 2	If the temperature is too high, turn off the light.	R3 (Turn off the light)	/	1.1kΩ	/	When the external NTC resistance decreases to R3, turn off the light and it needs to restart the AC to restore.
Internal over-temperature protection	Mode 1	If the temperature is too high, decrease the current first and then turn off the light.	T1 (Start to decrease the current)	82°C	85°C	88°C	When the internal temperature rises to T1, the internal thermal protection is triggered and the output current gradually decreases.
			T2 (Stop decreasing the current)	85°C	88°C	91°C	When the internal temperature rises to T2, the output current decreases to the programmed protection current value (default is 50%Io)
			T3 (Turn off the light)	88°C	91°C	94°C	When the internal temperature rises above T3, the lights are turned off, and when the temperature drops below T1, the lights can be automatically turned on.
	Mode 2	If the temperature is too high, turn off the light.	T3 (Turn off the light)	88°C	91°C	94°C	When the internal temperature rises above T3, the lights are turned off, and when the temperature drops below T1, the lights can be automatically turned on.
Open Circuit				<59V (AC needs to be powered off and restarted after 45S of open circuit)			
Short Circuit				Hiccup mode (auto-recovery)			

■ **Protective Characteristics**

Protective Type		Min.	Typ.	Max.	Introduction
Input Over-voltage Protection	Protective voltage	310Vac	320Vac	330Vac	When the input voltage is higher than the protection voltage, turn off the light.
	Restore voltage	261Vac	270Vac	278Vac	Auto-recovery mode. When the input voltage is lower than the recovery voltage, the driver can be automatically reset.

Remark: The recommended NTC model is NTSE0103FHM57A with a resistance of 10kΩ

■ **Protective Characteristics Schematic**

Schematic diagram of input overvoltage protection

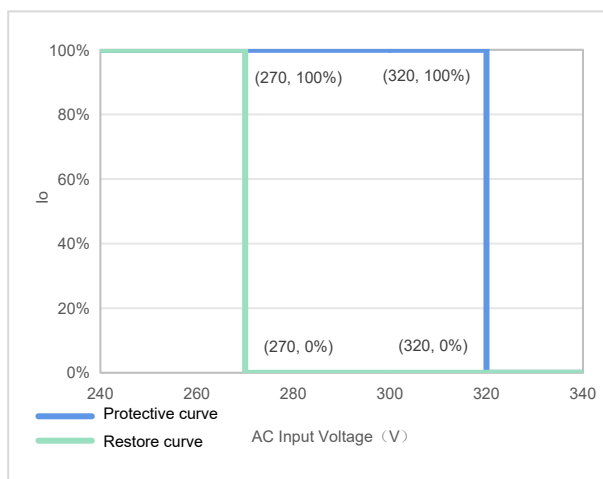

■ **Time Dimming Introduction**

Time dimming control includes 3 kinds of modes, they are Traditional Timer, Self Adapting-Midnight and Self Adapting Percentage. When the time dimming control starts, it will enter Traditional Timer mode by default. There are 6 segments in each mode, and you can set the brightness of each segment, the running time of the first to fifth segments, and the fade time for switching between the two segments.

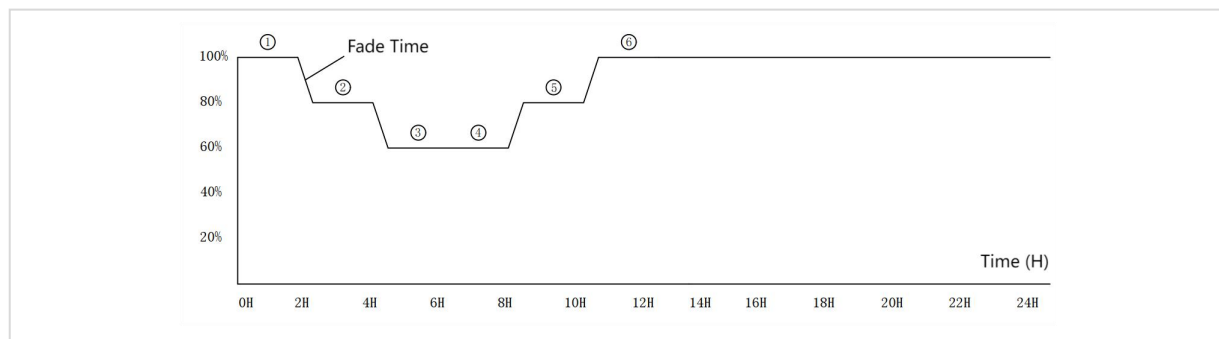

■ Time Dimming Introduction

Traditional Timer: Follows the programmed timing curve after power on.

Self Adapting-Midnight: Automatically adjusts the dimming curve based on the on-time of past 3 days (if difference <15 minutes), assuming that the center point of the dimming curve is midnight local time.

Self Adapting-Percentage: Automatically adjusts the on-time of each step by a constant percentage of the initialization time and operational use time according to the actual on-time for the past 3 days if difference <15 min).

■ Programmer Setting Instructions

① NFC



Note: When using an NFC reader, the driver is not allowed to operate while powered on. The driver must be powered off and completely discharged before it can read and write normally.

② Parameter setting box

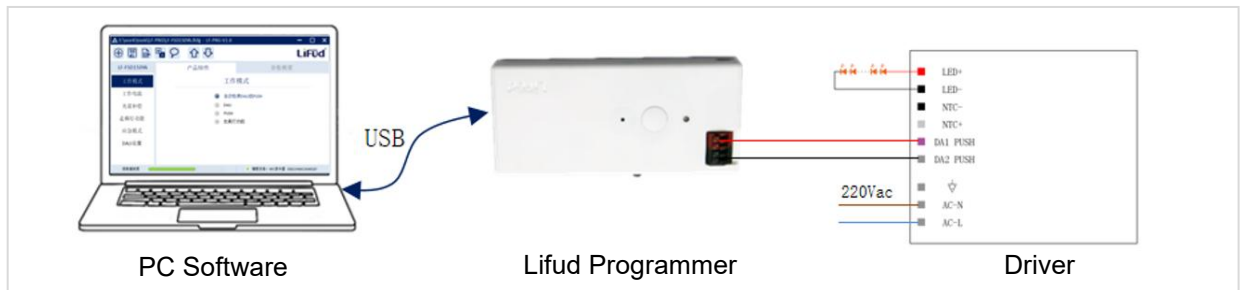

Note: When using the programmer, the driver must be powered on with AC for normal reading and writing.

Programmer tools and softwares

Type	Name	Brand	Model
Tool	NFC programmer	FEIG	ID CPR30+
	Lifud Programmer	LIFUD	LF-SCS080A
Software	NFC software	LIFUD	LF-NFCReader
	PC software	LIFUD	LF-PRG

Lifud Technology Co., Ltd.

Add.: 3AF, Block B, Xingzhan Plaza, No.446, Nanhuan Rd., Shajing St., Bao'an Dist., Shenzhen, Guangdong, China
 Factory I: Lifud Gardern-style Industrial Park, Tianfu New Dist., Meishan City, Sichuan, China
 Factory II: Lifud Intelligent Manufacture Industrial Park , Zhichuang Rd., Banfu Town, Zhongshan, Guangdong, China
 Website: www.lifud.com Telephone: +86(0)755 8373 9299 Email: sales@lifud.com

■ **Programmer Setting Instructions**

Read/write and parameter configuration

Programming project	Default settings	Parameters settings	Read/Write
Product information	-	No	Read
Output current	700mA (default)	Yes	Read/Write
Operating mode	DALI/PUSH	Yes	Read/Write
Time dimming	Inactivated	Yes	Read/Write
Over Temperature Protection	Activated	Yes	Read/Write

■ **Product Terminal Definition**

Product Terminals

INPUT		OUTPUT	
	Earth wire	LED+	Positive electrode output of LED driver
/	/	LED-	Negative electrode of LED board in series
/	/	NTC-	Negative electrode of NTC Temperature Sensor
AC-N	AC neutral wire input	NTC+	Positive electrode of NTC Temperature Sensor
AC-L	AC live wire input	DA1 PUSH	DALI 1/PUSH dimming input
/	/	DA2 PUSH	DALI 2/PUSH dimming input

■ **NTC/DALI Control Instructions**

Wiring Diagram of NTC/DALI Dimming

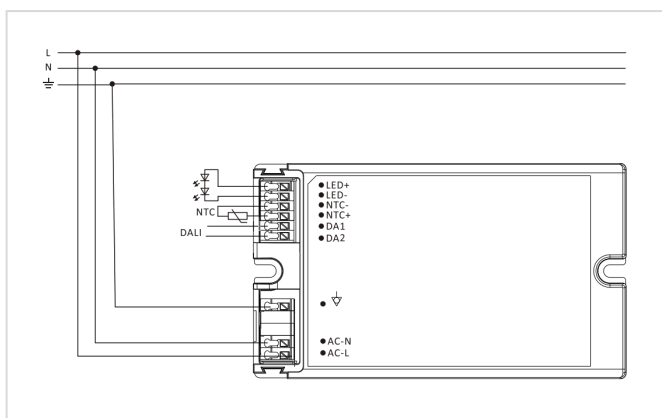

Operations of DALI Dimming

- Default setting brightness is 100%.
- Connect DALI signal to DA1 PUSH and DA2 PUSH.
- DALI protocol includes Max. 16 scene groups.
- Maximum number of LED drivers connected in parallel in DALI dimming mode: 64 pcs.
- Dimming depth of DALI dimming: 3%.
- When DALI OFF, reset within 10s of power failure to keep OFF state.

■ NTC/DALI Control Instructions

DALI Dimming Curve

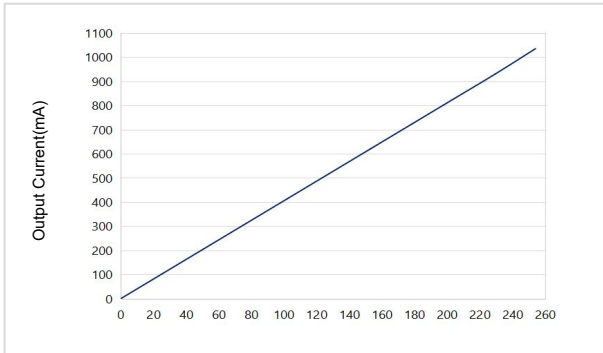

linear dimming

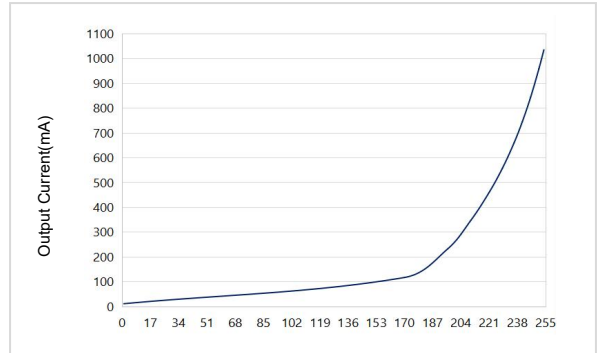

logarithmic dimming

- ⚠ Choose only ONE as opposed to use DALI or PUSH at the same time in case of the damage of DALI dimmer.

■ Operations of PUSH Dimming

Wiring Diagram of PUSH Dimming

Remarks

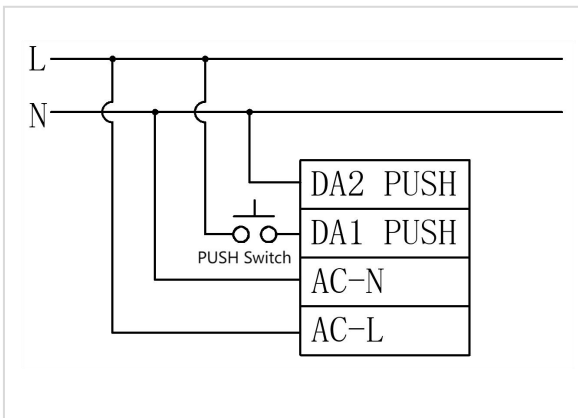

- Connect PUSH switch between AC-L and DA1 PUSH in series and connect DA2 PUSH to AC-N.
- Make sure that AC-L and AC-N are NOT directly connected to DA1 PUSH and DA2 PUSH terminals.
- Make sure that PUSH switch is off before the AC is powered on; operate PUSH after the AC is powered on.
- Make sure the PUSH switch is off before disconnecting the AC.
- If you have any questions about the wiring and operation, please confirm with Lifud FAE.
- ⚠ Wrong wiring or operation may cause damage to the driver.

Operation	Duration	Function
Instant Push	0.1-0.5 sec	LED light on/off
Long Push	0.6-9 sec	LED light dim up/down
Reset Push	>9 sec	Reset the brightness of luminaire to 50%

- The PUSH operation won't cause any variations on LED driver if it's less than 0.1S.
- Minimum dimming depth of PUSH dimming: 3%
- The PUSH dimming mode has the memory function in case of any power failure. When the LED driver is powered on again, the light will return to the previous state before power failure.
- The present dimming direction of PUSH dimming is opposite to the former one.
- Max. wire length from the PUSH switch to the farthest LED driver: 135m; wire diameter: 12-24AWG.

Lifud Technology Co., Ltd.

Add.: 3AF, Block B, Xingzhan Plaza, No.446, Nanhuan Rd., Shajing St., Bao'an Dist., Shenzhen, Guangdong, China
 Factory I: Lifud Gardern-style Industrial Park, Tianfu New Dist., Meishan City, Sichuan, China
 Factory II: Lifud Intelligent Manufacture Industrial Park, Zhichuang Rd., Banfu Town, Zhongshan, Guangdong, China
 Website: www.lifud.com Telephone: +86(0)755 8373 9299 Email: sales@lifud.com

■ **Structure & Dimensions (unit: mm)**

Model	Overall Appearance (L*W*H)	Distance Between 2 Positioning Holes (L)	Diameter of Positioning Hole (D)
LF-ACD040A-1050-57	132.6*76.5*33 mm (±0.5mm)	122.5 mm (±0.5mm)	4.5 mm

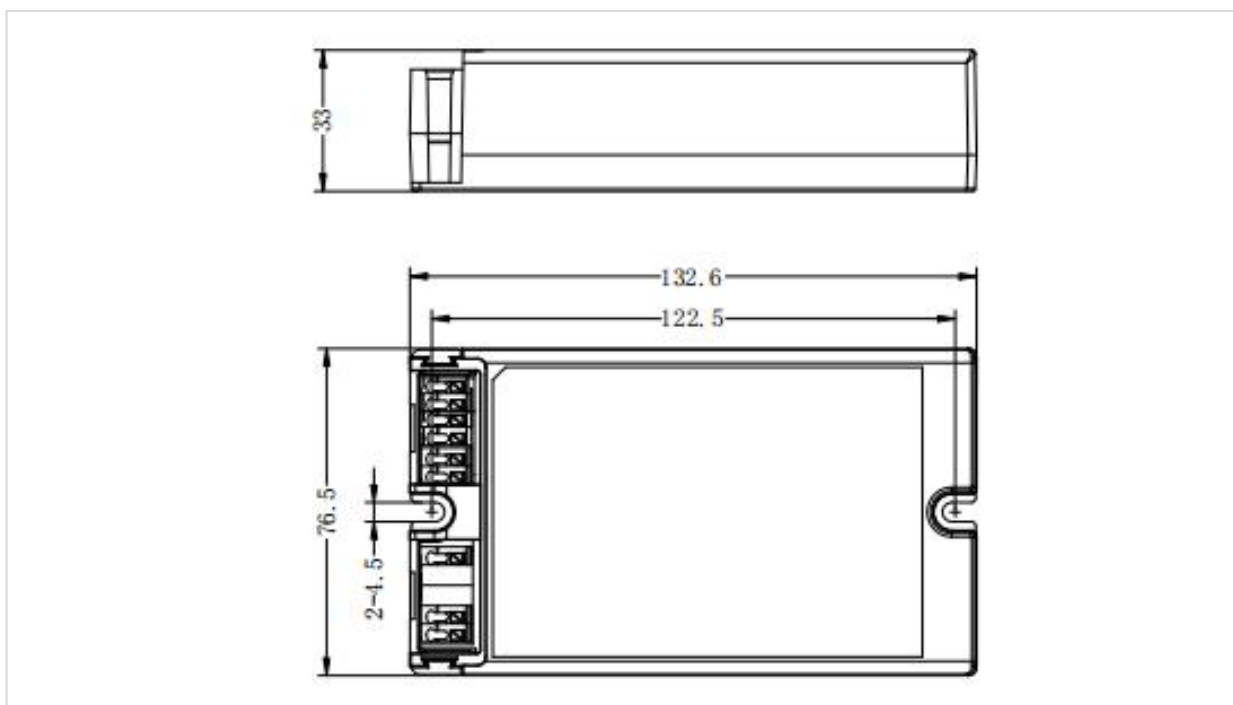

■ **Packaging Specifications**

Model	LF-ACD040A-1050-57
Carton Size	320*320*178mm (L*W*H)
Quantity	12 pcs/layer; 2 layers/ctn; 24 pcs/ctn
Weight	0.207 kg ± 5% /pc; 5.8 kg ± 5% /ctn

■ Transportation and Storage

1. Transportation

- Suitable transportation means: vehicles, boats and aeroplanes.
- In transit, it is necessary to prepare awnings for rain or sun protection. Moreover, please keep civilized loading and unloading to prevent the vibration or impact of LED driver as much as possible.

2. Storage

- The storage of LED driver shall conform to the standard of Class I environment. When using LED drivers which have been stored for more than 6 months, please re-test them firstly. Do not use them unless they are tested to be qualified.

Cautions

- Please use Lifud LED driver according to its parameters in the specification, otherwise the LED driver may malfunction.
- Using any incompatible light fixtures or those that have not been certified may cause fire, explosion or other risks.
- Man-made damage is beyond the scope of Lifud warranty service.

Remark: Lifud Technology Co., Ltd. reserves the right to interpret any contents of this specification.